



HARVEY
BUILDING PRODUCTS

Enclosure Systems





Accu-Fit Enclosure System

The Classic Vinyl Accu-Fit Enclosure System is a non-load bearing wall system providing maximum flexibility and ease of installation. Rolling, double hung, picture window or casement can be used in the system. The structural receiver frame uses heavy, thermally broken aluminum extrusions. Prices include full screens with fiberglass wire and stainless steel installation screws. Door options include the Harvey vinyl patio door and the Therma-Tru Smooth-Star door with Schlage Series F Plymouth lockset and deadbolt keyed alike.

Vertical Section

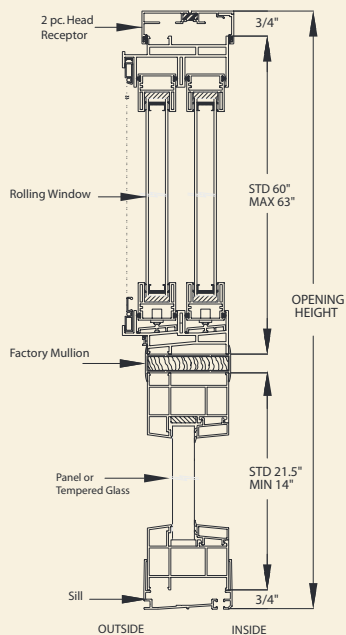

- For openings that are plumb, level and square (tolerance of 1/4")
- Maximum opening width 75"; Maximum height 100"
- Classic vinyl rolling window standard
- Custom sized to fit each opening
- Options include double hung, picture window or casement
- Kneewall glazed with 7/8" tempered glass or 7/8" insulating foam panel
- Includes snap-fit, thermally broken aluminum receptor system
- Available in White, Almond, Bronze
- Kneewall (solid or glass) available in White, Almond or Bronze

Horizontal Section

2-piece structural mounting frame w/rolling window

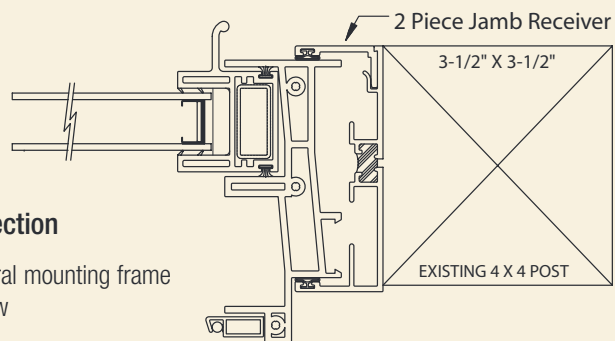

Aluminum Enclosure System

The Harvey Aluminum Enclosure System provides an economical method for enclosing existing porches. The glass may be either one or two piece tempered panels that are interchangeable with screens or they can be windows that operate horizontally or vertically including screens. These panels are 1-1/8" in depth and are held in place with H and F channels. The standard door is a matching outswing storm door.

FIXED GLASS/SCREEN COMBO



Hollywood

Hi-Lite

- Custom size, modular system fills virtually any opening without filler panels
- Interchangeable glass inserts and aluminum screens
- Includes H and F style channeling
- Choice of Hollywood or Hi-Lite style panels
- Outswing or inswing operating door
- Panels with standard or custom size kick plates
- Max. individual panel width 40"
- White, Almond or Bronze baked enamel finish

PANELS W/ OPERABLE SASH



- Horizontal Rolling – DuPont Delrin wheels, spring loaded sash locks and full aluminum screen set up
- Vertically Operating – Tru-Channel storm window with self storing** design and aluminum half screen
- White, Almond or Bronze baked enamel finish
- Includes H and F style channeling
- Custom sizes will fit most any opening



**Only bottom sash vents.
Sash & screen do not drop into bottom of door

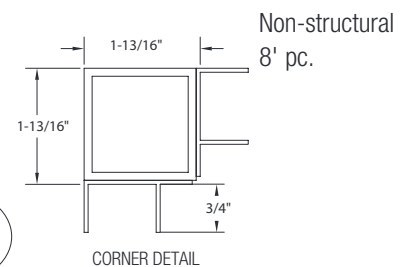
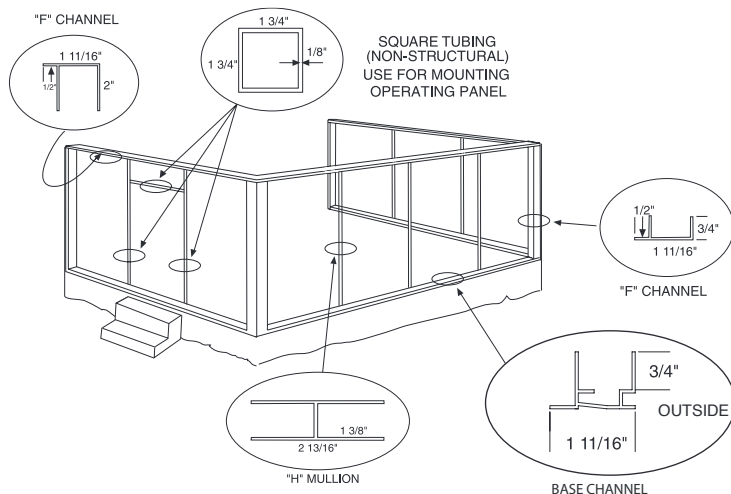

While Harvey Aluminum Enclosures are designed to provide ventilation and protection from insects, they are not completely weatherproof and therefore are not intended for prime living areas.



HARVEY
BUILDING PRODUCTS

About Harvey Building Products

Harvey has built a solid reputation as a leading manufacturer and distributor of quality building products. A privately owned and operated business with over 50 years' experience, Harvey Building Products is known for outstanding craftsmanship and superior service as well as standing behind every product we make. In addition to manufacturing durable, attractive windows, doors and porch enclosures, Harvey distributes a full line of highly respected building products to professional contractors and builders throughout the Northeast.

We understand what it takes to be part of your home.™



Harvey Building Products
1400 Main Street
Waltham, MA 02451-1623 USA
800-9HARVEY (800-942-7839)



Information about Harvey Building Products and our products and services can be found at harveybp.com.

Follow us:    

16-024

